

SGGC



After installing this lift kit, the front wheels must be properly aligned. Failure to properly align the front wheels may result in decreased ability to control the Golf Cart which may result in a rollover or crash.

SGC ALL TERRAIN

LIFT KIT

FITS CLUB CAR PRECEDENT

HD ALL TERRAIN LIFT KIT INSTALLATION INSTRUCTIONS

CLUB CAR PRECEDENT

After installing this lift kit, the front wheels must be properly aligned. Failure to properly align the front wheels may result in decreased ability to control the golf cart which may result in a rollover or crash.

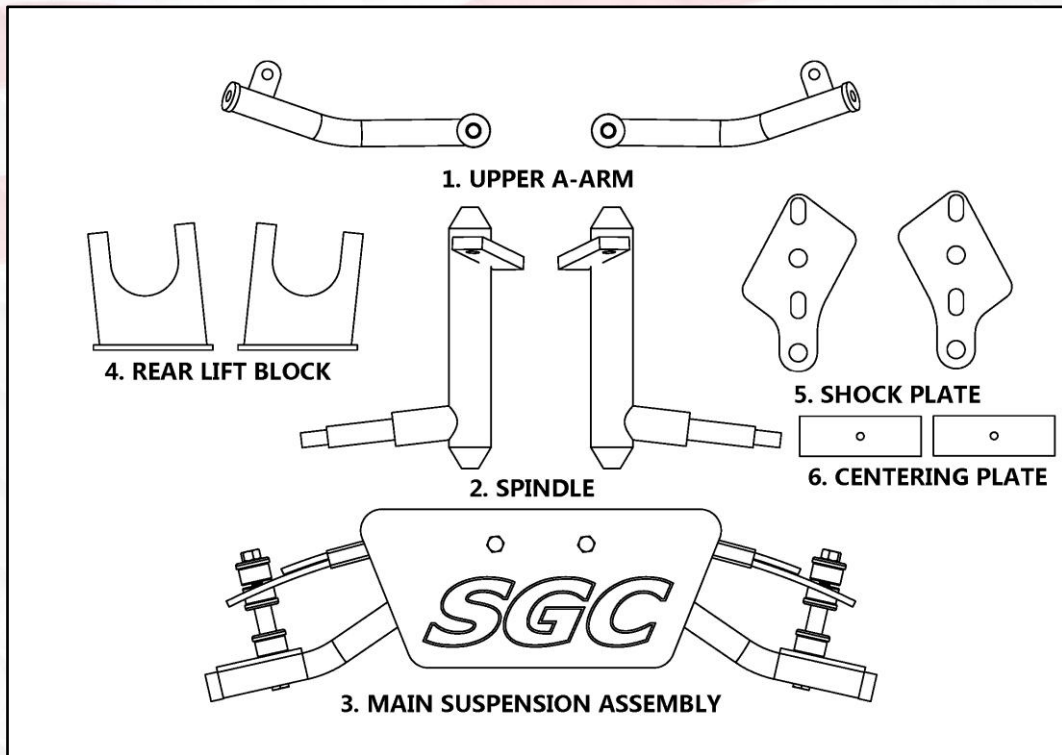

CHECK LIST FOR HARDWARE (Bolt in bag#12 too long so packed separately)				
	NO#	SPEC	QTY	
front suspension	7	HEX BOLT	5/16-18*2	2
		FLAT WASHER	5/16	4
		LOCK NUT	5/16	2
	8	HEX BOLT	M10x1.5-45	4
		FLAT WASHER	M10	4
	9	EGG NECK BOLT	1/2-20*50	4
10	NUT	1/2-20	6	
11	HEIM JOINT		4	
rear suspension	12	HEX BOLT	7/16-14*7 1/8	4
		LOCK NUT	7/16	4
		FLAT WASHER	7/16	8
	13	HEX BOLT	1/4-1/2	2
		FLAT WASHER	1/4	4
	LOCK NUT	1/4	2	

Reserve the right to change the parameters without prior notice.

HD ALL TERRAIN LIFT KIT INSTALLATION INSTRUCTIONS CLUB CAR PRECEDENT

To begin, be sure to engage the parking brake and switch your cart to "off". Also make sure RUN/TOW switch is in TOW position.

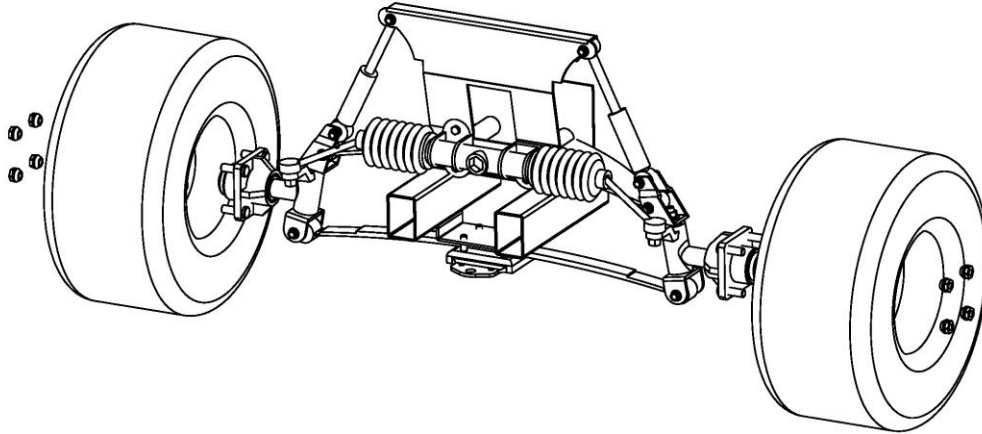

1. Remove lug nuts when cart on ground. Then raise the cart with jack stands under the frame. Remove wheel from the hub. Detach front bumper and retain hardware.

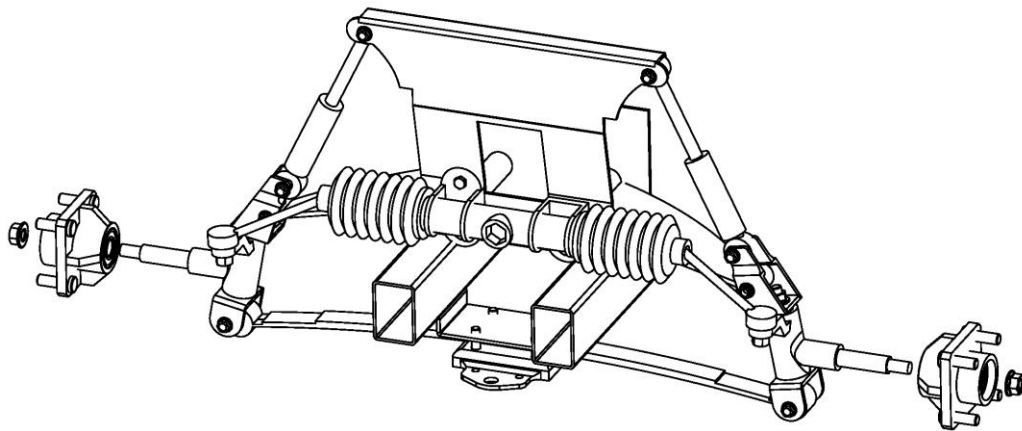

2. Using a 21mm socket remove and retain hub and flange nut. Repeat on passenger side.

HD ALL TERRAIN LIFT KIT INSTALLATION INSTRUCTIONS CLUB CAR PRECEDENT

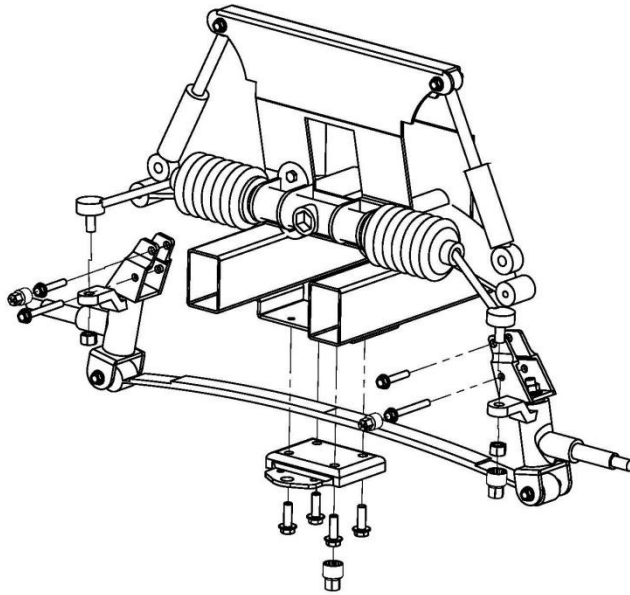

3. Using a 1/2" socket remove bolt from shock and discard. Push shock up and out of the way. Remove and retain the cotter pin from tie rod end, using an 18mm socket and 11/16" wrench. Remove nut from tie rod.

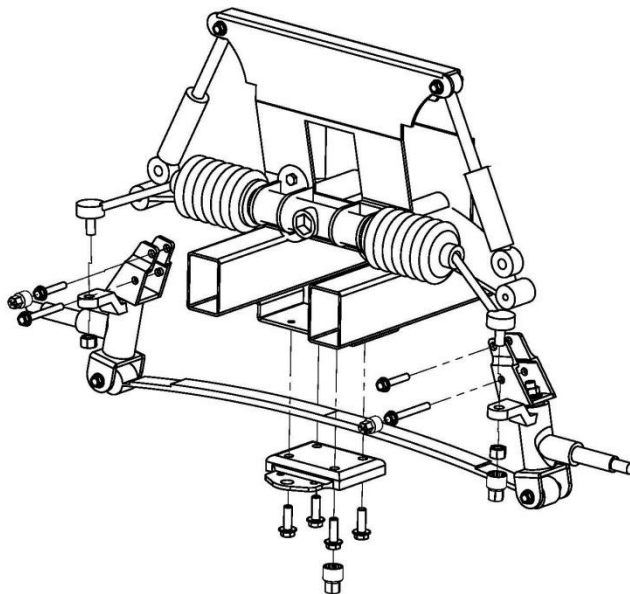

4. Using 1/2" socket remove factory spindle. Using a 1/2" socket remove spring plate and leaf spring. Retain spring plate, discard hardware and leaf spring.

HD ALL TERRAIN LIFT KIT INSTALLATION INSTRUCTIONS CLUB CAR PRECEDENT

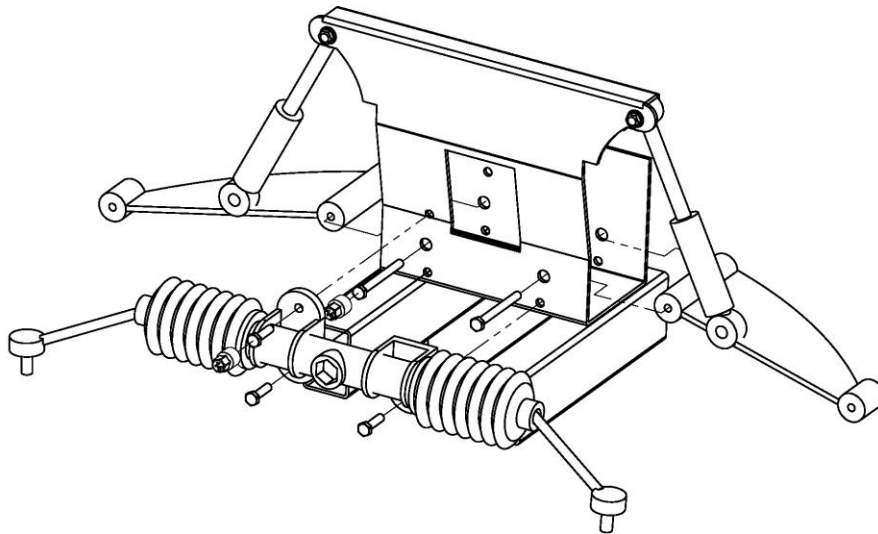

5. Using a 1/2" socket remove 3 bolts securing rack and pinion. Retain hardware. You will not completely remove rack and pinion. This step is to gain access to upper A-arm bolts. Using a 1/2" socket remove factory A-arms. Retain hardware.

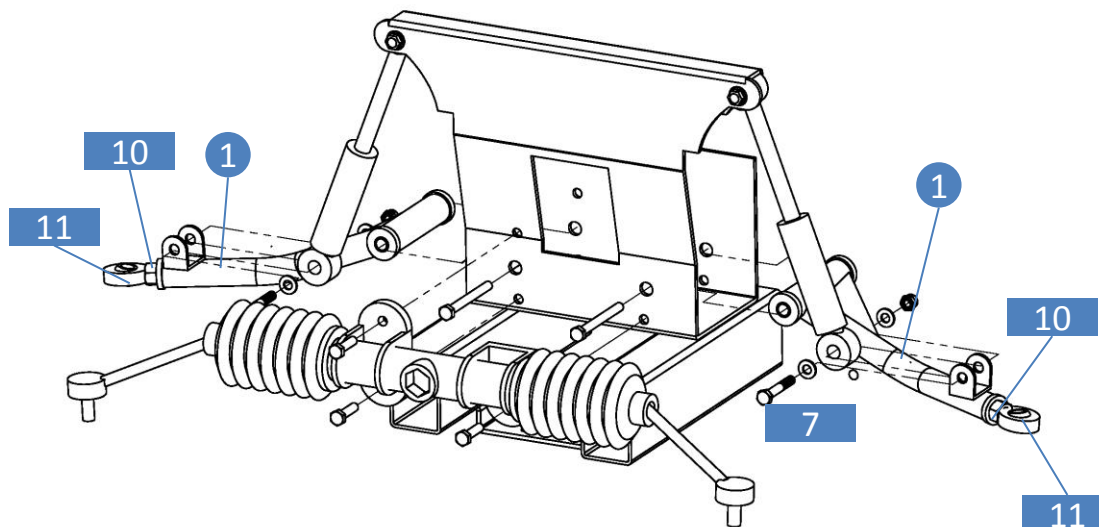

6. Install supplied upper a-arm #1 to cart with hardware from last step. Install heim joint #11 and nut #10 to upper a-arm. Install factory shock to upper a-arm with supplied hardware #7 5/16-2 bolt washer and nut.

HD ALL TERRAIN LIFT KIT INSTALLATION INSTRUCTIONS CLUB CAR PRECEDENT

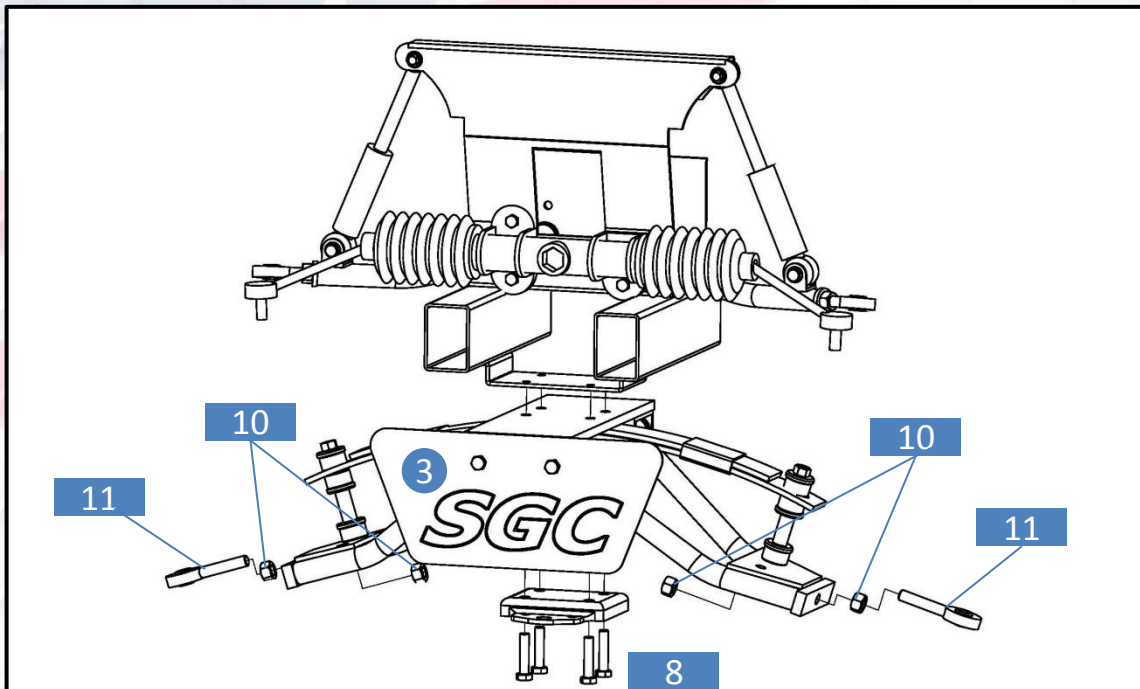

7. Using spring plate from step 4. Attach new main suspension assembly #3. Use supplied #8 hex bolts and washers to secure to cart. Before attaching spindles, install and adjust heim joints so there is approximately 1/4" of thread showing.

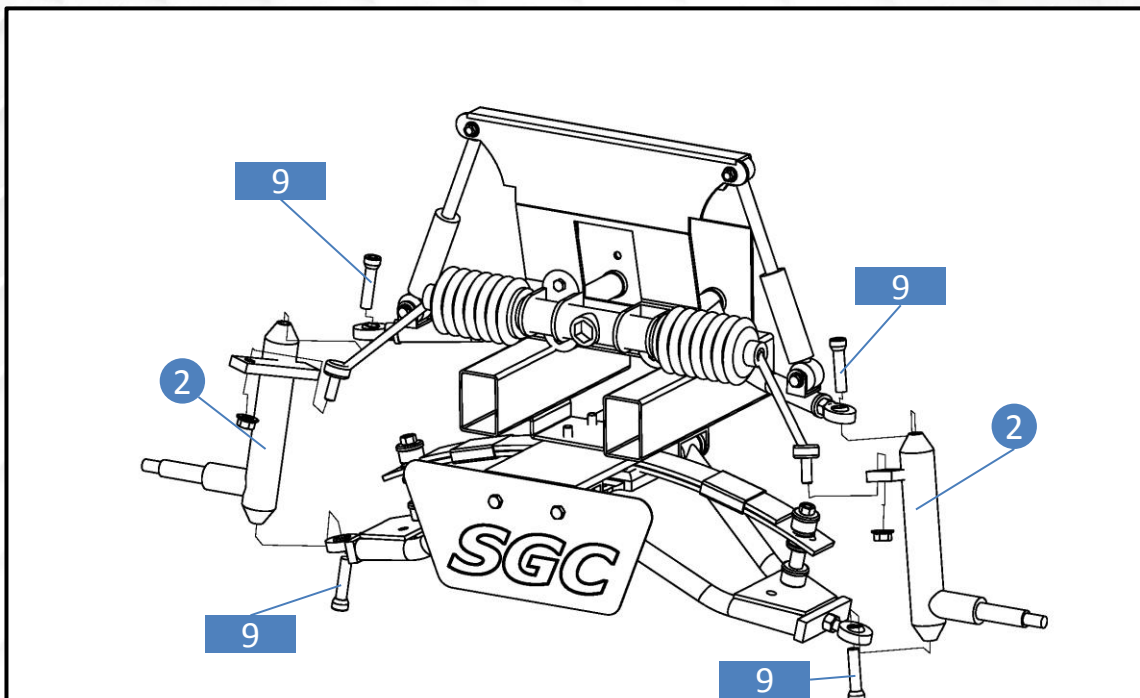

8. Attach spindles #2 to main suspension assembly #3 and upper a-arms using supplied egg neck bolt #9. Don't use thread locking adhesive until alignment is completed. Reattach tie rod to spindles using retained castle nut and cotter pin.

HD ALL TERRAIN LIFT KIT INSTALLATION INSTRUCTIONS
CLUB CAR PRECEDENT

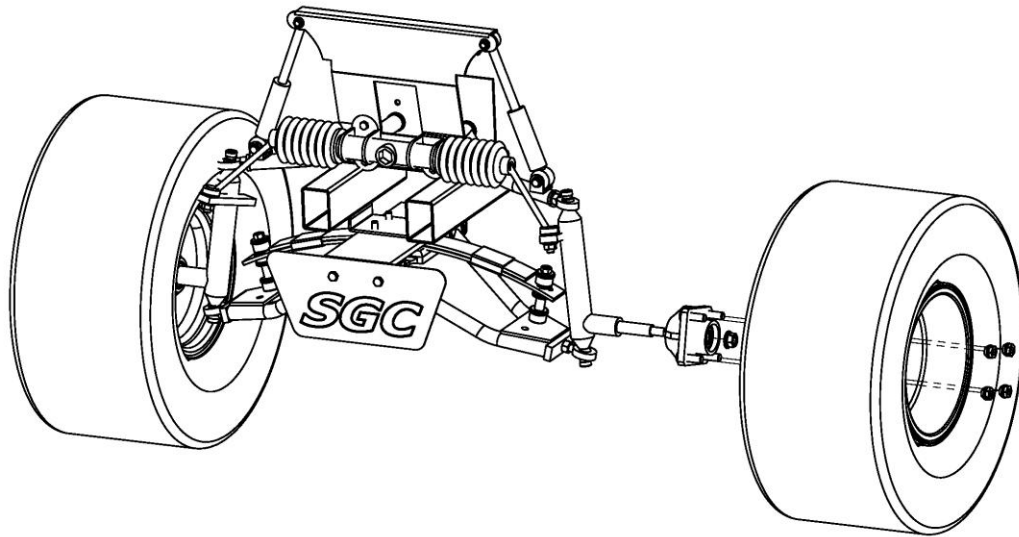

9. Reattach hub using hardware retained from step 2. Reinstall bumper . Install new wheels and lower cart.

HD ALL TERRAIN LIFT KIT INSTALLATION INSTRUCTIONS CLUB CAR PRECEDENT

Chock front wheels, then disengage parking brake. Lift rear of Cart and support with jack stands under the frame. Remove rear wheels. Leave jack in place under axle and motor assembly.

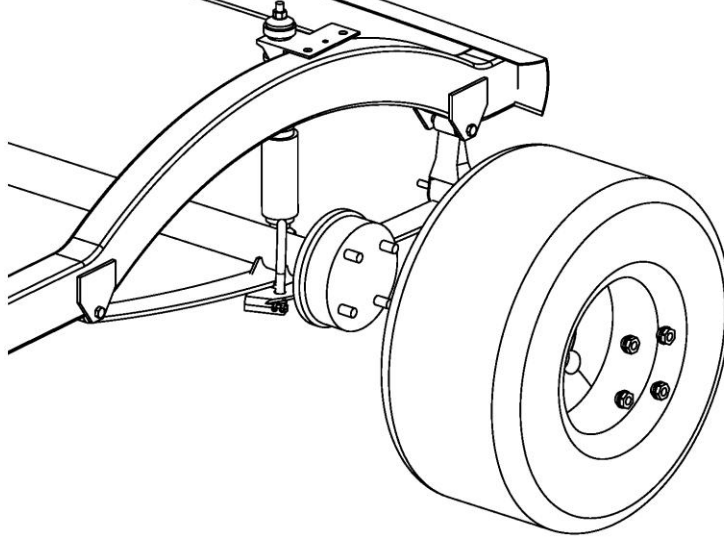

10. Remove rear wheels.

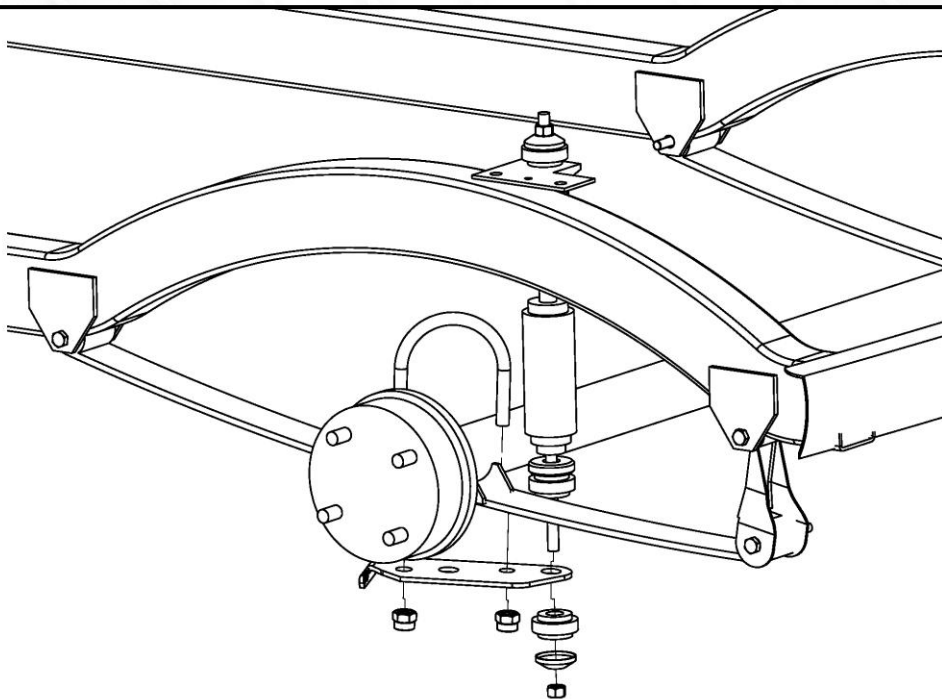

11. Using a 5/8" socket loosen the U-bolts on the passenger side. Don't remove the U-bolts. It's important to do one side at a time to avoid motor roll. Loosening but not removing the U-bolts will make this easier.

HD ALL TERRAIN LIFT KIT INSTALLATION INSTRUCTIONS CLUB CAR PRECEDENT

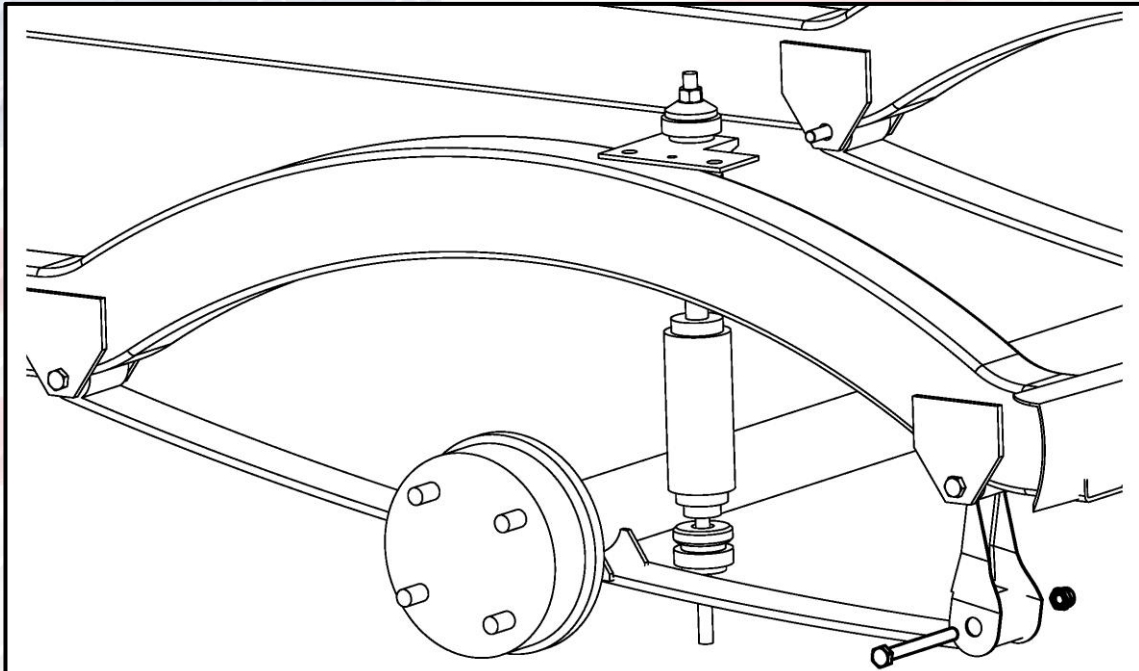

12. Using a 10mm socket and 13mm wrench remove hardware from rear leaf spring mount and front leaf spring mount. Retain hardware.

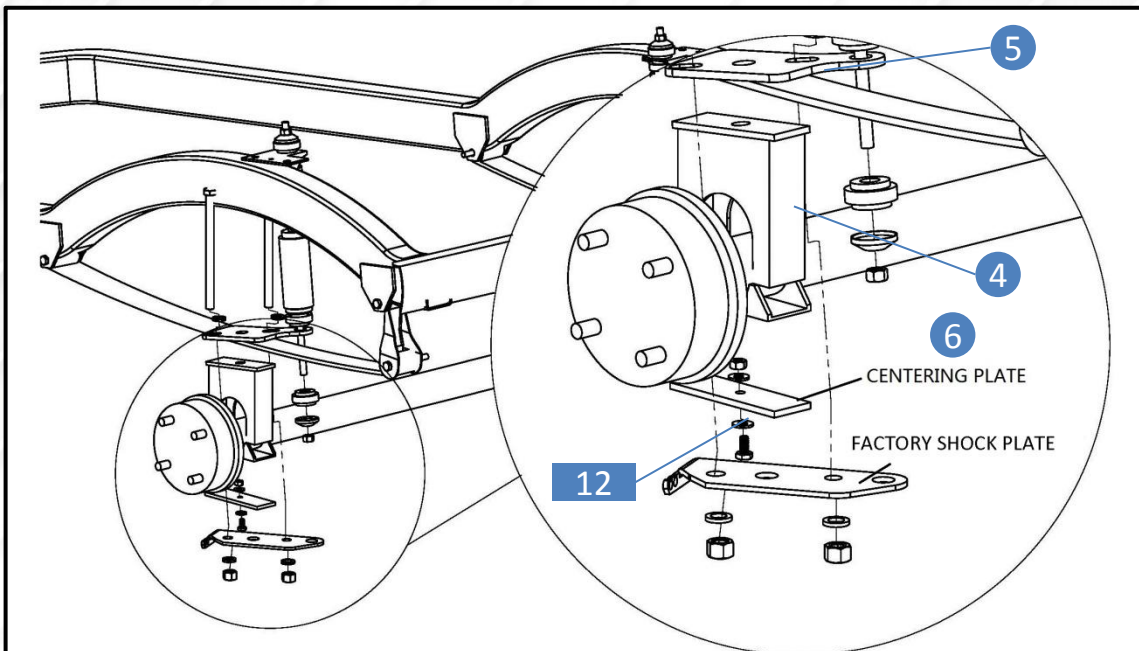

13. Place rear lift block #4 on the axle and under leaf spring. Ensure that top of lift block angles down toward the front of cart. Place rear shock plate #5 over leaf spring and attach shock to it. Attach hardware #13 on centering plate #6 then attach centering plate to factory shock plate. The bolt head and nut will fit into the center hole of the spring perch and factory shock plate to aid in alignment of the riser and mounting plates.

HD ALL TERRAIN LIFT KIT INSTALLATION INSTRUCTIONS CLUB CAR PRECEDENT

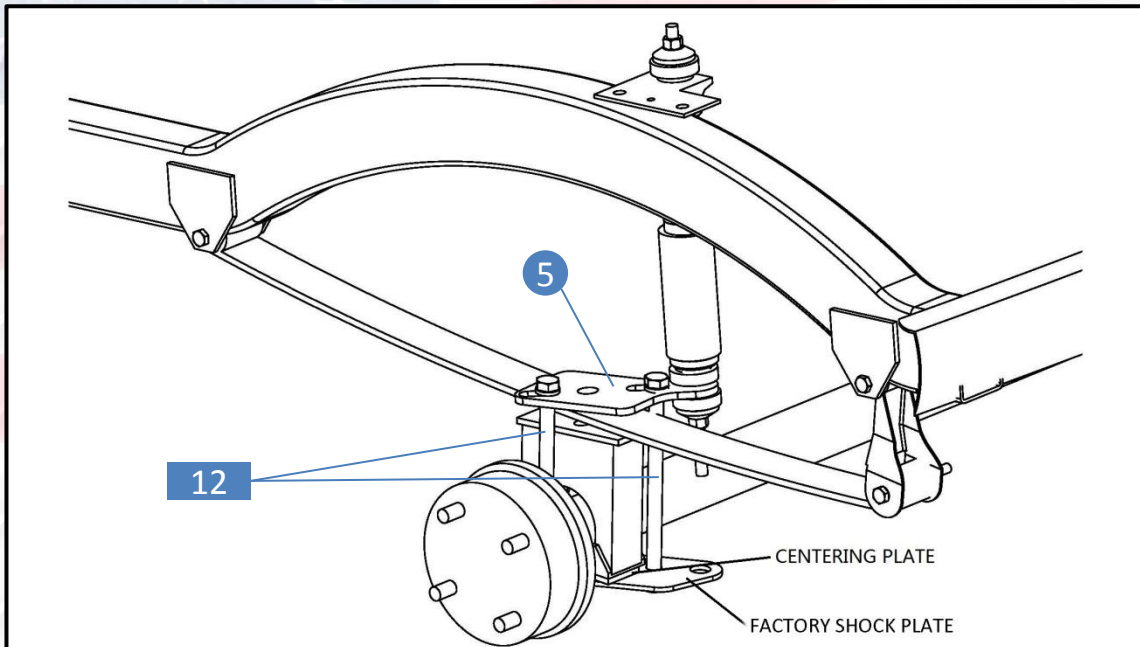

14. Route supplied #12 bolts M12*180 through rear shock plate#5, rear lift block and factory shock plate. Using socket to tighten these four bolts evenly to ensure proper alignment.

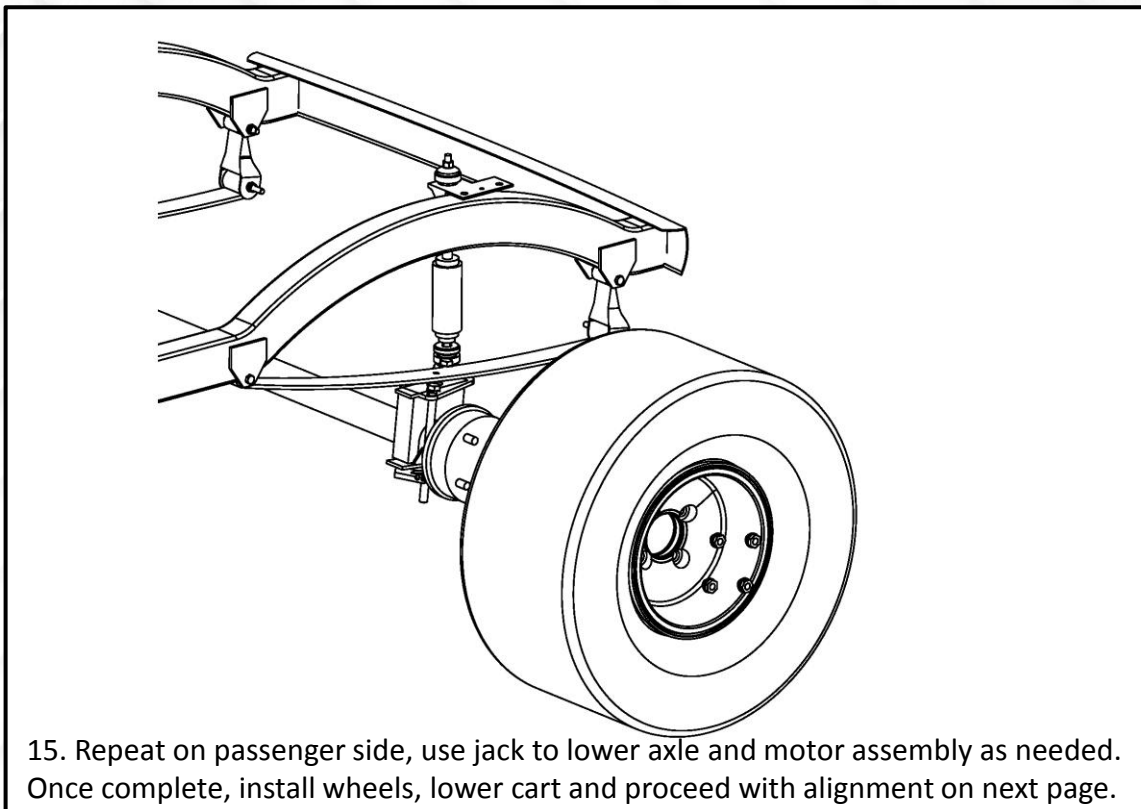

15. Repeat on passenger side, use jack to lower axle and motor assembly as needed. Once complete, install wheels, lower cart and proceed with alignment on next page.

ALIGNMENT INSTRUCTIONS CLUB CAR PRECEDENT

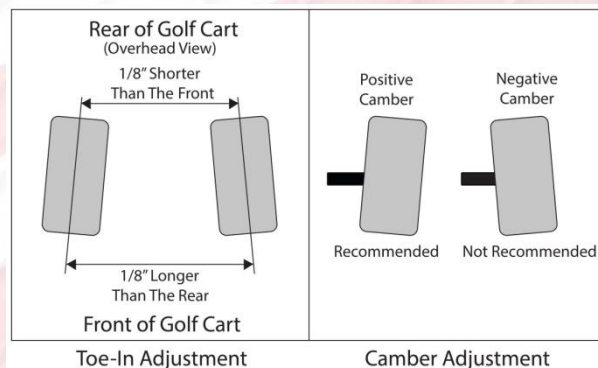
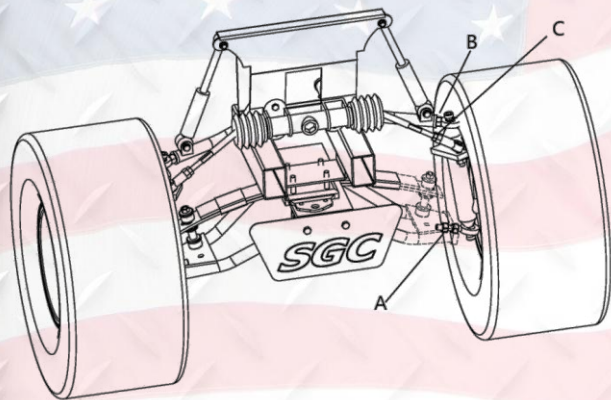

IMPORTANT: Both Camber and Toe must be adjusted on this model.

To adjust for proper camber (the vertical tilt of the wheels), use a framing square, level, or some other means of verifying that the tire is at a 90 degree angle to the ground.

Adjust camber to 90 degrees using the two nuts on the bottom heim joint.

If adjusting the camber to 90 degrees is not possible using only the adjustment on the bottom heim joint, then the top heim joint must be disconnected from the spindle, rotated, then reassembled and checked as necessary to achieve the correct camber.

IMPORTANT: Be sure to retighten all adjustment points after adjustments are made.

To adjust Toe, ensure the wheels are pointing straight forward. Find a common point to measure from on the inside front and inside rear of the front tires. Adjust until the front measurement is 1/4" to 3/8" greater than the rear measurement. Loosen nut on both tie rod ends. Adjust using a wrench to desired alignment.

If steering wheel is not properly oriented after adjusting toe-out, adjust steering box tie rod to align steering wheel if needed. Loosen tie rod lock nuts and turn steering box tie rod clockwise or counter clockwise to adjust steering wheel.

IMPORTANT: Ensure that after this adjustment, both wheels toe out from the cart's centerline equally. Once tightened, roll the cart back 15-20 feet and then forward again to check.

NOTE: Be sure to use thread locking adhesive on upper and lower heim joint spindle screws.



RETURN MERCHANDISE AUTHORIZATION

Dear Valued Customer,

Thank you for choosing Steelang Golf Cart Accessories for your golf cart needs.

We apologize for the issues you are having with your purchase. We strive to offer the absolute best quality at the absolute best price.

To best serve you, we do need a little information to help process your return and/or exchange faster.

Please complete the following and include this entire form with your return.

Name

Shipped To Address

STATE

ZIP

Purchased with: eBay Direct Phone Order

This is for EXCHANGE REFUND

Please describe reason for return:-

Our Return Address:

Steelang Golf Cart Accessories

3309 Laurens Road,

Greenville, SC 29607

Tele: 864-675-1103

For Office Use Only:

Received By: _____

Date _____

Refund Amount _____

Exchange Issued _____

**Steelang Golf Cart Accessories reserves the right to charge a 15% restocking fee for all returned and/or exchanged items.