

SGC



SGC DROP AXLE

LIFT KIT

FITS EZGO TXT 01.5+, ELEC

Product is subject to change without prior notice.

LIFT KIT INSTALLATION INSTRUCTIONS

EZ-GO 2001.5 & NEWER TXT, ELEC

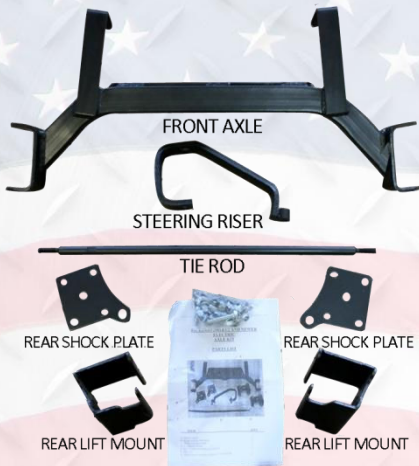

Part List	Hardware	
Front axle	1	Hex Bolt M12*50 2
Steering riser	1	Nylon Nut M12 2
Tie rod	1	Hex Bolt M10*30 8
Rear shock plate	2	Nylon Nut M10 8
Rear lift mount	2	

FRONT INSTALLATION

1. Jack up the front end of the cart and place it on jack stands. You will be installing larger wheels and tires so raise the cart high enough to accommodate for the additional height.
2. Remove the wheels and tires. Remove the tie rod end at the spindle that attaches to the steering box. Remove the spindles from the front axle. Clean and lubricate these bolts and bushings for the reinstallation of the spindles. The two stock mounting holes on the spindle of the passenger side needs drilled out to 1/2" for installation of the **steering riser**.
3. Remove the front axle from the leaf springs. Clean and lubricate the bolts for installation of the new axle.
4. Using the bolts from the old axle install **front axle** to the leaf springs.
5. Install the spindles to the new front axle.
6. Install **steering riser** to the passenger side spindle using the M12*50 bolts and nuts provided. Reattach the tie rod joints to the spindles. **NOTE: SOME E-Z-GO MODEL CARTS COME STOCK WITH A TIE ROD LONG ENOUGH! IF THE STOCK TIE ROD JOINTS DO NOT HAVE GREASE FITTINGS FROM WHEEL TO WHEEL YOU WILL NEED TO INSTALL THE TIE ROD IN THIS KIT.**
7. Securely tighten all bolts. Install recommended 22 x 11-10 wheels and tires with a 3 x 5" offset for maximum performance and stability. **NOTE: Your stock wheels and tires will NOT work!**
8. Take the cart off of the jack stands and lower the cart. Drive the cart forward 10-20 feet and check the toe-in. (Proper toe-in should be approximately 1/8".)



steering riser

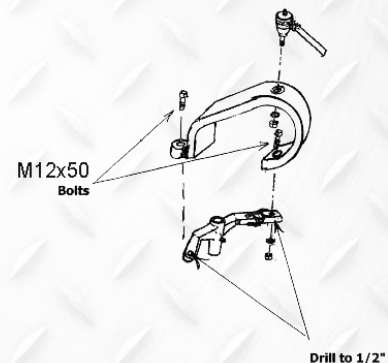

LIFT KIT INSTALLATION INSTRUCTIONS

EZ-GO 2001.5 & NEWER TXT, ELEC

REAR INSTALLATION

1. Jack up the rear end of the cart and place jack stands on the frame in front of the springs. Place a car jack under the rear-end housing. You will be installing larger wheels and tires so raise the cart high enough to accommodate the additional height.
2. Remove the wheels and tires. Unbolt the bottom of the shocks. Clean and lubricate these bolts for later use.
4. Unbolt the rear leaf springs from under the rear end. Save the front and rear leaf spring bolts for reinstallation of the leaf springs. Using the car jack lower the rear end of the cart.
5. Place **rear lift mounts** on top of the axle as shown. NOTE: Parts are universal. There is no left or right side.
6. Place the leaf springs on top of the risers and loosely mount the front of the leaf springs to the stock front leaf spring mount using the stock hardware.
7. Place **rear shock plate** on top of the leaf springs with the shock mount holes facing the rear of the cart and towards the center. Using the supplied M12 bolts and locknuts mount the rear shock mounts to the rear lift mounts with the leaf springs sandwiched in between them. The bolts go through the new rear shock mount, rear lift mounts, and stock shock mount. Make sure you tighten these bolts evenly.
8. Using the stock leaf spring bolts and nuts, bolt the rear leaf spring to the stock rear leaf spring mount. Attach the bottom of the shocks to new shock mounts on the rear shock mounts using the stock nuts and bolts.
9. Use wire ties to fasten the brake cable to either the underside of the springs or the frame.
10. Securely tighten all nuts/bolts. Install recommended wheel and tire size 22 x 11 x 10 wheels and tires with a 3 x 5" offset for maximum performance. NOTE: Your stock wheels and tires will work but are **not** recommended!

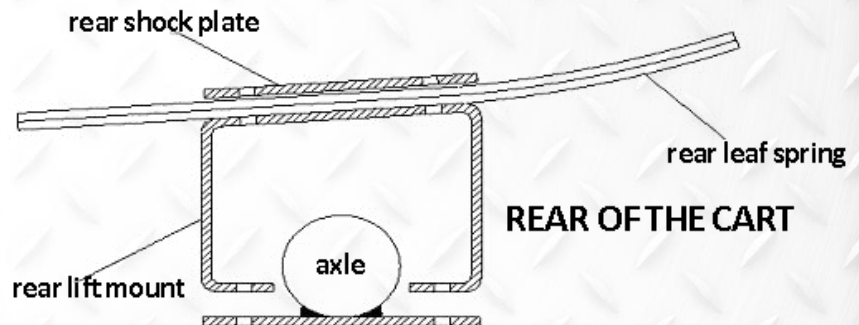



RETURN MERCHANDISE AUTHORIZATION

Dear Valued Customer,

Thank you for choosing Steeleng Golf Cart Accessories for your golf cart needs.

We apologize for the issues you are having with your purchase. We strive to offer the absolute best quality at the absolute best price.

To best serve you, we do need a little information to help process your return and/or exchange faster.

Please complete the following and include this entire form with your return.

Name

Shipped To Address STATE _____ ZIP _____

Purchased with: eBay Direct Phone Order

This is for EXCHANGE REFUND

Please describe reason for return:-

Our Return Address:
Steeleng Golf Cart Accessories
3309 Laurens Road,
Greenville, SC 29607
Tele: 864-675-1103

For Office Use Only:

Received By: _____

Date _____

Refund Amount _____

Exchange Issued _____

**Steeleng Golf Cart Accessories reserves the right to charge a 15% restocking fee for all returned and/or exchanged items.